

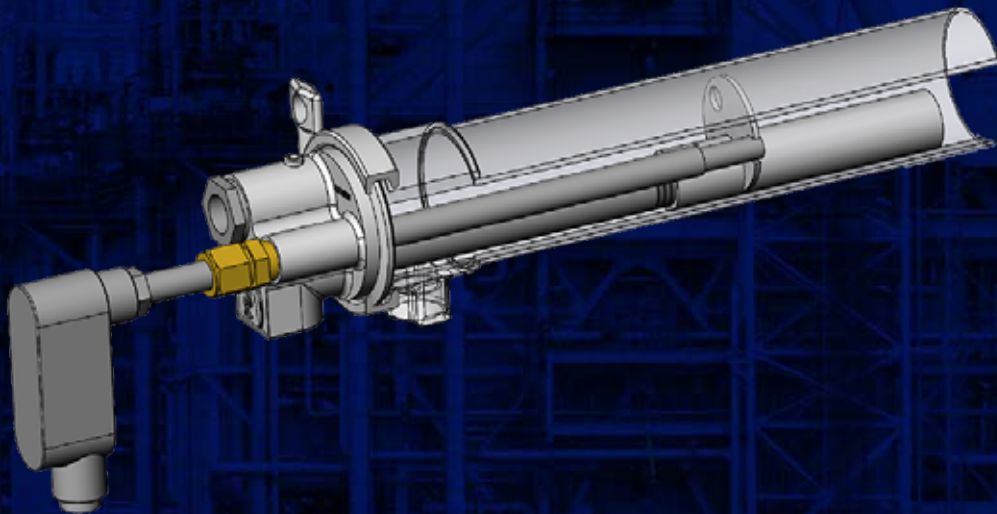

**MAXFire® Series 100
Gas Igniters Manual**

Publication 372001-04 Rev. D

- BURNERS
- IGNITERS
- DAMPERS
- CONTROLS



www.forneycorp.com

INTRODUCTION

This manual contains information for the MAXFire® Series 100 Igniter from Forney Corporation, 16479 North Dallas Parkway, Suite 600 Addison, TX 75001.

All personnel should become thoroughly familiar with the contents of this manual before attempting to install, operate or maintain the MAXFire® Igniter system. Because it is virtually impossible to cover every situation that might occur during operation and maintenance of the equipment described in this publication, personnel are expected to use good engineering judgment when confronted with situations that are not specifically mentioned herein.

The user should update this manual whenever significant changes are made to the system. To be of value, the manual must always reflect the latest configuration of the equipment. It should be noted, however, that Forney Corporation will furnish updated pages only if Forney authorizes a modification and accomplished under Forney supervision.

PROPRIETARY NOTICE

The contents of this publication are proprietary data of Forney Corporation. Reproduction or use of any part of the publication for purposes other than the support of the equipment for which it is published is permissible only if expressly authorized in writing by Forney.

Additional copies of this publication may be purchased from Forney. When ordering or requesting cost information, refer to the publication number appearing on the title page. Address to the attention of the Sales Department, Forney Corporation, 16479 North Dallas Parkway, Suite 600 Addison, TX 75001.

REVISIONS

REVISIONS	DATE	COMMENTS
A	05/04/2010	Initial Release
B	10/25/2010	Updated Capacity Rating for MAXFire 135
C	02/09/2015	Update logos, contact info, Spec table-MaxFire35 gas supply
D	12/15/2020	General Redesign

TABLE OF CONTENTS



TABLE OF CONTENTS

Section 1 Description	1
1.1 Spark Ignition Source	2
1.2 View Port	2
1.3 Mount Tube	2
Section 2 Specifications	4
Section 3 Safety	5
Section 4 Installation	6
4.1 Mount Tube / Guide Tube	6
4.2 Fuel and Air Piping	7
Section 5 Commissioning	9
5.1 Igniter Flame Detection	9
Section 6 Troubleshooting	10
Section 7 Maintenance	11
7.1 Guide Tube	11
7.2 Igniter	11
Section 8 Storage	12
Section 9 Return or Repair Service	13
Section 10 Spare Parts	14
TABLE OF FIGURES	
Figure 1-1 MAXFire® Gas Igniter AssemblyGuide Tube Assembly	1
Figure 1-2 Typical MAXFire® Mount Tube Assembly	3
Figure 4-1 Igniter Tip Arrangement	7
Figure 4-2 Typical Fuel Piping Arrangement	8
LIST OF TABLES	
10-1 Recommended Spare Parts List	15

SECTION 1

DESCRIPTION

The MAXFire® gas igniter is a versatile and reliable source of ignition energy for oil, coal, or natural gas burners. It is a self-contained unit that features a stable and clean-burning flame, repeatable fuel ignition, low maintenance (no moving parts), and low combustion/cooling air requirements.

Depending on the burner capacity, the MAXFire® gas igniter may be sized for use as an NFPA-rated Class 1, Class 2, or Class 3 igniter. Class 1 igniters are used for burner light off and support. Class 2 igniters are used for light off and support under prescribed light off conditions. Class 3 igniters are used for light off only and are not intended for warm-up or support.

MAXFire® igniters are available in a variety of hardware configurations to fit the customer's installation requirements and operating preferences. In addition to the standard assemblies, other capacities can be provided on request.

The major components of the igniter assembly are a guide tube, ignition source, and view port. Figure 1-1 illustrates a typical arrangement of the MAXFire® igniter assembly.

Figure 1-1 MAXFire® Gas Igniter Assembly

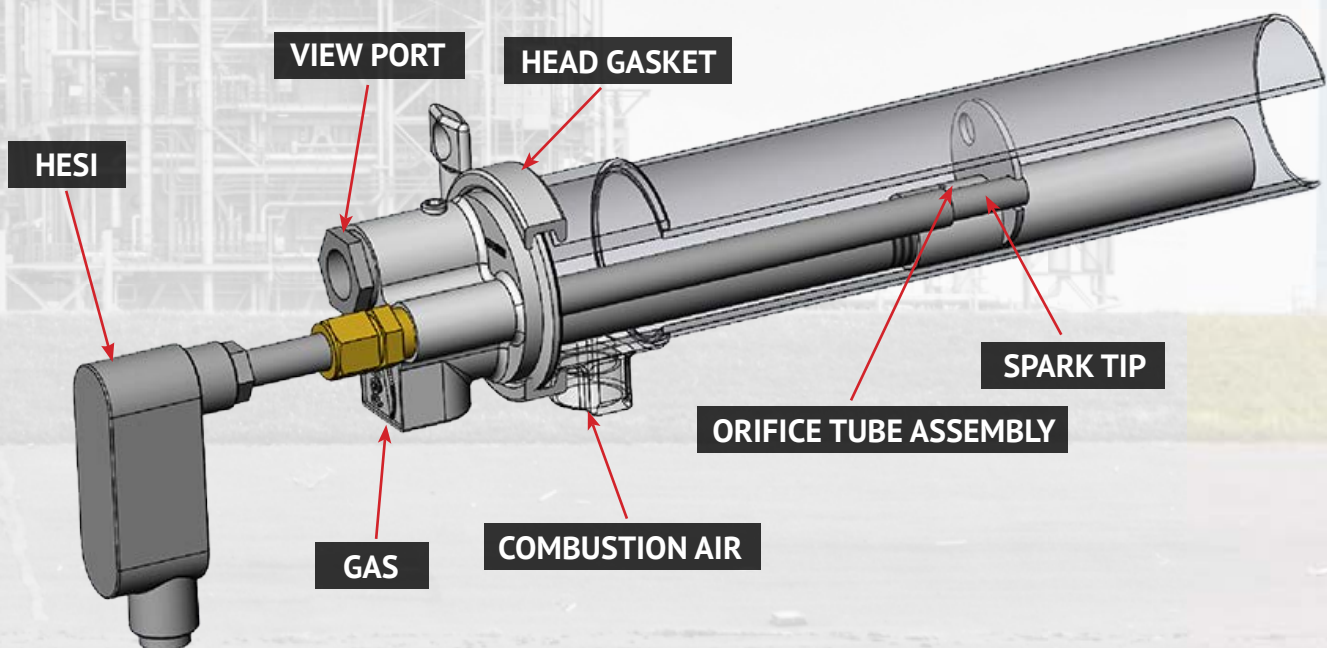

Guide tube lengths are available from 14 to 180 inches in 2-inch increments. The guide tube assembly houses the following major parts of the igniter:

- Gas tube
- Spark Ignition Source
- Orifice tube assembly

1.1 SPARK IGNITION SOURCE

The igniter port of MAXFire® igniter can be fitted with:

- Forney High Energy Spark Igniter (HESI Series 90 or Series 90EC for European applications)
- High Tension Spark Igniter (HTSI)

Refer to the service manual for the HESI Series 90, HESI Series 90EC or HTSI for more detailed information.

1.2 VIEW PORT

The standard MAXFire® igniter includes an integral view port through the igniter head.



CAUTION: Forney does not recommend the use of the view port for flame detector sighting. If this location is utilized, Forney's initial start-up procedure should be adhered to in its entirety. Reference Section 5 Commissioning.

1.3 MOUNT TUBE

In most applications, the MAXFire® igniter is mounted on a burner through a mount tube.

The mount tube (Figure 1-2) is welded to the burner front-plate and supports the igniter assembly. The igniter guide tube slides into the mount tube and is secured in place by a split clamping ring (squeeze collar) that is bolted or welded to the mount tube. The squeeze collar also serves as a packing gland follower.

Figure 1-2 Typical MAXFire® Mount Tube Assembly

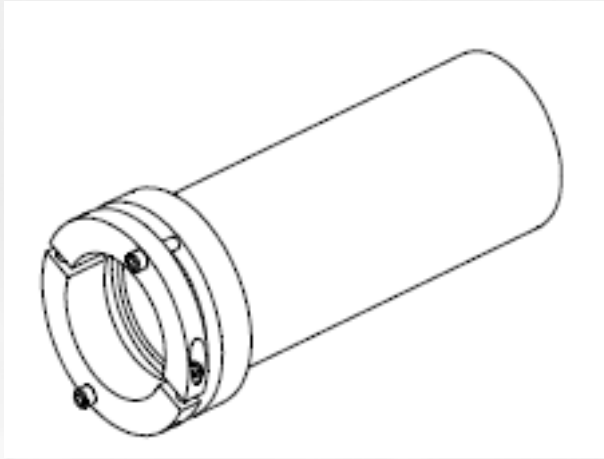

MAXFire® Model	Mount Tube Outside Diameter
110	2.13"
130	3.5"
135	4.0"
140	4.5"
150	5.5"

SECTION 2

SPECIFICATIONS

Specifications for each MAXFire Igniter are defined below:

	MAXFire 110	MAXFire 130	MAXFire 135	MAXFire 140	MAXFire 150
Fuel	Natural gas				
Fuel heating value	1000 Btu/ft ³				
Guide tube OD	1 7/8"	2 7/8"	3 1/2"	4"	5"
Capacity rating	0.3 to 0.5 MMBtu/hr @ 2 psig 0.2 to 1.5 Mbtu/hr @ 10 to 15 psig	1.5 to 6 MMBtu/hr @ 10 to 25 psig (orifice size dependent)	5 to 10 MMBtu/hr @ 10 psig 11 to 15 MMBtu/hr @ 15 to 20 psig	5, 10, and 15 MMBtu/hr @ 15 psig 20 and 25 MMBtu/hr @ 25 psig	25 to 50 MMBtu/hr @ 15 to 25 psig
Gas inlet port	1/2" NPT	3/4" NPT	1 1/2" NPT	1 1/2" NPT	2 1/2" NPT
Cooling/combustion air	23 scfm	45 scfm	50 scfm	80 scfm	120 scfm
Cooling/ combustion air pressure	3.0 to 6.0 inches w.c. above wind box pressure measured at the sight port/scanner				
Air inlet port	3/4" NPT	3/4" NPT female	1 1/2" NPT	1 1/2" NPT female	2" NPT female
Ignition source	HESI, Series 90; HESI, Series 90EC; or HTSI				
NFPA Class	1, 2, or 3				
Recommended gas supply hose size	3/4" ID	1" ID	1 1/2" ID	1 1/2" ID	2 1/2" ID
Gas line strainer	0.033 inch NPT female				

SECTION 3

SAFETY

Forney makes every effort to include personnel safety as a basic design element of the MAXFire® igniter. However, safety is the responsibility of each individual who installs, operates or maintains Forney equipment. Observe the following safety instructions prior to performing installation, operation, or maintenance instructions:

1. Use this equipment for its intended purpose only.
2. Follow the installation, operation, and maintenance procedures discussed in this publication and on appropriate drawings.



CAUTION: The igniter should be sized, arranged, and tested per NFPA 85. Job-specific installation instructions, arrangement and installation drawings are available as an option.

3. Ensure that all electrical tools are in good working order and has been calibrated correctly.
4. Do not disconnect grounding cables/wires while equipment is energized.
5. Do not perform modifications to the equipment.
6. Before opening the HESI power unit, disconnect the electrical supply from the power source. Allow at least 2 minutes for the capacitor to discharge. Exercise extreme care when the power unit is open. Refer to the HESI Service Manual for safety instructions for HESI equipment.
7. Ensure that no voltage is present prior to disconnecting any terminations.
8. Close the manual fuel shutoff valves before performing maintenance or troubleshooting procedures.
9. On pressurized furnace applications take precautions prior to removing the igniter to ensure hot furnace gases do not escape from the boiler possibly creating a hazard. Forney recommends use of aspirators on all igniters installed on pressurized furnaces.
10. Test all fuel pipe connections for leaks before placing system into service.
11. Ensure the igniter assembly and the HESI power unit or the HTSI transformer are connected to a common ground.
12. When removing the igniter assembly from an operating furnace, wear protective clothing and insulated gloves. While observing the igniter flame through an open observation port, wear a face shield and protective clothing.



WARNING: Only knowledgeable and qualified technicians should be allowed access to this system or its components. The installation, maintenance, and operation of the electrical equipment involve several elements of danger. **Carelessness can result in serious injury or death from electrical shock, falls, or improper use of tools and test equipment.**

SECTION 4

INSTALLATION

4.1 MOUNT TUBE / GUIDE TUBE

Typically, the mount tube is fixed permanently to the burner front plate and supports the igniter assembly. The design of the MAXFire® igniter allows the user to weld the guide tube directly to the burner front plate, if desired.

1. Cut a hole through the burner front plate in the location desired or as indicated on the installation drawing. The diameter of the hole should be slightly larger than the outside diameter of the mount tube.
2. Insert the mount tube through the front plate and into the burner area. Support the mount tube at the position and penetration angle required or indicated on the optional installation drawing. During retrofit or replacement applications, insert the MAXFire® igniter to the same location as the previous igniter. As a general rule, the tip of the igniter should be 3 inches ($\pm 1/8$ ") behind a vertical plane through the position of the main burner fuel nozzle.
3. Seal-weld the mount tube to the burner front plate. On some older installations where cast iron plates must be penetrated, a steel flange or cover plate can be bolted to the cast iron, so that the mount tube can be welded to that flange or plate. When installing the guide tube, avoid contact with internal burner parts, such as air vanes or burner sleeves. Occasionally, air vanes may have to be trimmed in order to provide clearance for the mount tube.
4. Before tightening the mount tube squeeze collar, rotate the guide tube to accept flexible hose connection for cooling/combustion air. Tighten the nuts of the squeeze collar to hold the guide tube securely in position.
5. Before inserting the guide tube into the mount tube, inspect the primary combustion region for cleanliness and check the position of the spark rod tip. Figure 4-1 illustrates the correct position of the spark rod tip.

Figure 4-1 Igniter Tip Arrangement

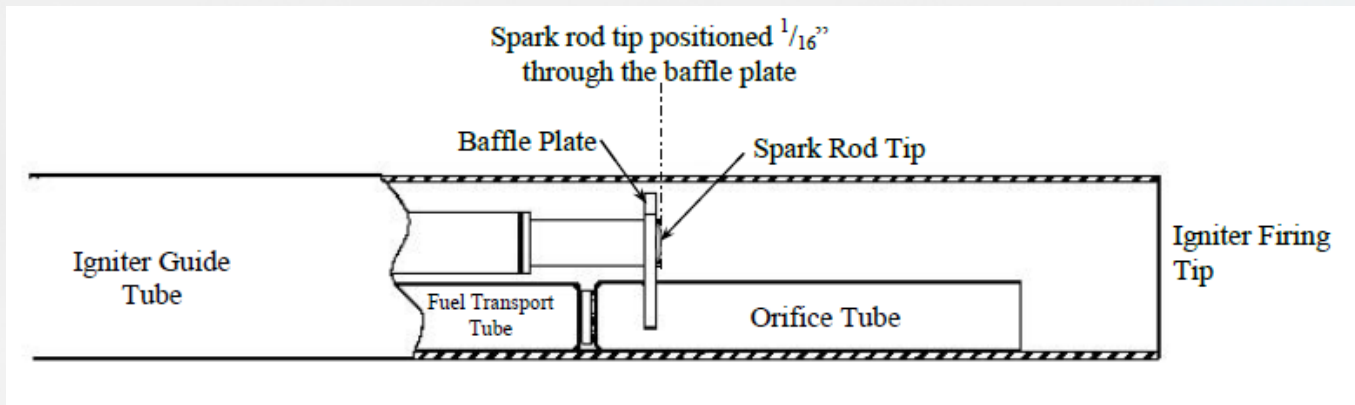

4.2 FUEL AND AIR PIPING

Forney recommends using the following general guidelines regarding fuel and air piping.



NOTE: In applications for boilers with multiple igniters and burners, equal air and gas flow distribution to each igniter are important for reliable and efficient operation. Care should be exercised in the design of fuel and air headers to obtain uniform distribution under all flow conditions.

1. To prevent contamination of the igniter, ensure that all fuel and air piping and hoses have been blown free of debris and moisture. During installation, tap off the gas header from the top or side to help prevent contamination.
2. Install gas pressure regulators in the gas headers to ensure that the specified pressure is maintained at the igniter. Ensure that the selected regulator has the required turndown capacity and response time capability needed for this application. Install strainers upstream to protect regulator from debris.



CAUTION: Install flexible hoses between the rigid supply headers to the igniter that allow adequate length for maximum thermal expansion of the boiler.

3. Position igniter as needed to accept the flexible hose from air and gas supply. Ensure that all bends in the flexible hose are in the same plane. Figure 4-2 illustrates a typical piping arrangement.

Figure 4-2 Typical Fuel Piping Arrangement

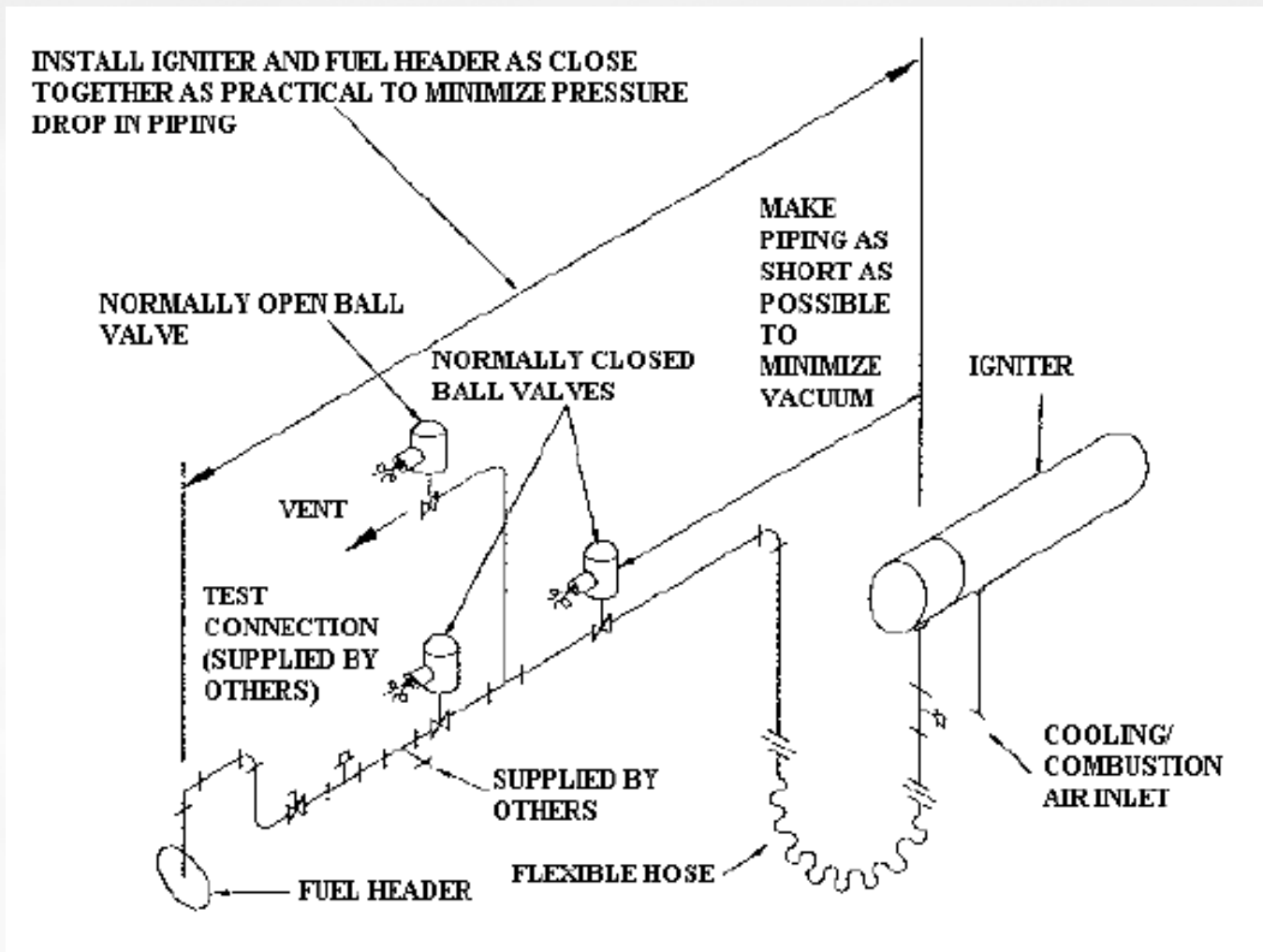

SECTION 5

COMMISSIONING

Before commissioning the MAXFire® igniter, complete all steps in the Installation section of this manual. Use the following checklist to ensure that the MAXFire® igniter is ready for initial operation.

- _____ The mounting tube adequately supports the igniter assembly.
- _____ The igniter assembly has been checked for clearance within the burner and does not interfere with dampers, vanes, or any other moving parts.
- _____ Adequate igniter assembly removal distance exists.
- _____ The muffle area and gas orifices have been inspected and are free of dirt / debris.
- _____ The HESI spark trip is in the correct location (Figure 3).
- _____ All fuel and air piping have been blown clean and free of debris and moisture.
- _____ The HESI was independently tested and works properly.
- _____ All wiring and logic interlocks have been field-tested for proper operation.
- _____ Adjust the cooling/combustion air manual valve to supply proper airflow. (reference Specifications section of this manual).
- _____ Adjust the pressure regulator on the igniter gas header to obtain the necessary pressure at the igniter inlet.

5.1 IGNITER FLAME DETECTION

The igniter flame can be detected by a flame detector or flame rod located on the rear of the igniter or separately mounted flame detector on the burner front. The igniter should always be started by qualified personnel to test the igniter for proper light off, reliability, and compliance to NFPA 85 Code.

New igniters MUST always be started on a cold furnace to ensure all design parameters are correct and the flame propagates to the fuel dump tube properly. It is highly recommended that a Forney Field service engineer perform the initial startup to ensure safety and reliability of this product.



CAUTION: For Class 1, 2, or 3 igniters detecting flame down the guide tube of the igniter solely from the back of the igniter may or may not be sufficient to prove an igniter flame. The application must be proven at start-up. The purchaser is responsible to test as appropriate to satisfy NFPA.

SECTION 6

TROUBLESHOOTING

If the igniter fails to ignite, confirm that the following conditions exist:

- All manual valves in the gas and the air lines for this igniter are in their proper position.
- All automated valves in line with this igniter are operating correctly.
- The specified gas pressure is confirmed at the inlet to the igniter gas tube.
- The specified cooling/combustion air flow is confirmed at the inlet to this igniter.
- The ignition source (HESI or HTSI) is installed in the correct position (Figure 3) and is producing sparks. If the HESI or HTSI fails to generate sparks, refer to the HESI or HTSI Service Manual for additional guidance on fault isolation.
- The two fuel orifices in the orifice tube assembly are free of obstructions.

If the igniter establishes a flame but fails to remain ignited, confirm that the following conditions exist:

- The fuel supply pressure at the inlet to the igniter remains at the specified level during/following igniter light off.
- The flow of cooling/combustion air is maintained at the specified level during/following igniter light off.
- Airflow in the burner wind box is not extinguishing the flame or moving the flame out of the flame detector sighting region.
- The flame detection device is operating correctly.

SECTION 7

MAINTENANCE

The following components of the MAXFire® igniter require periodic maintenance. Proper care of these components ensures long and reliable service.



WARNING: On pressurized furnace applications take precautions prior to removing the igniter to ensure hot furnace gases do not escape from the boiler possibly creating a hazard. Forney recommends use of aspirators on all igniters installed on pressurized furnaces.

7.1 GUIDE TUBE

During a planned boiler outage inspect the furnace end of the guide tube for overheating. If evidence of overheating is present, the igniter may be inserted too far forward with respect to the main burner. Refer to the Installation section for instructions on igniter placement. If the problem persists, contact Forney for assistance.

7.2 IGNITER

The igniter internals should be removed from the guide tube every 12 months or during a scheduled boiler outage and examined as follows.

1. Close the manual gas shutoff valve in line with this igniter.
2. Disconnect the gas line from the inlet to the gas tube.
3. Disconnect the electrical cable from the HESI or HTSI.
4. Remove the guide tube clamp from the igniter head.
5. Inspect the HESI or HTSI electrode for any buildup of deposits. Refer to the HESI or HTSI Service Manuals for maintenance requirements of the spark rod.
6. Carefully remove the internal components of the igniter from the igniter guide tube. If evidence of heat distortion is observed, the flow of cooling air to the igniter may be impaired, or the igniter may be positioned too far forward in the burner. Make the necessary adjustments to airflow or igniter positioning.
7. Unscrew the orifice tube assembly from the gas tube. Examine the orifices for evidence of clogging or accumulation of debris. Use a soft wire to clean the orifices as required.
8. After inspecting and cleaning, reassemble the igniter, connect fuel line, electrical cables, and adjust valves to proper positions.

SECTION 8

STORAGE

Store the MAXFire® igniter in a clean, dry environment. When possible, store the igniter in its original shipping container until it is installed. If the MAXFire® igniter is removed from its shipping container, store it in a horizontal position supported at both ends of the guide tube. Cover the MAXFire® igniter with plastic to keep it free from dust and dirt.

SECTION 9

RETURN OR REPAIR SERVICE

Forney Corporation warrants this product to be free of defective material and workmanship. Forney will repair or replace this equipment if it is found to be defective upon receipt, but not later than 90 days from the date of shipment.

Prior to returning any material to Forney, a Return Material Authorization (RMA) identification number must be obtained from Forney. Clearly mark the RMA number on all shipping containers and accompanying documents. Forney accepts only materials submitted in accordance with these RMA instructions.

To issue an RMA, Forney must have the following information:

- List of equipment to be returned by stock number/model number.
- Reason for return.
- Company name and address of the customer.
- Customer's requested mode for return shipping.
- Customer's purchase order number for repairs (if applicable).
- Customer's requested return date.
- Name and address to which Forney is to return-ship and any special container marking information that may be required.
- Name of individual (customer's representative) requesting the RMA.

Any one of the following methods may be used to obtain an RMA:

Phone: (972) 458-6100 or 458-6142

1-800-356-7740 (24-hour direct line)

Fax: (972) 458-6600

FORNEY CORPORATION IS NOT RESPONSIBLE FOR MATERIALS RETURNED WITHOUT PROPER AUTHORIZATION AND IDENTIFICATION.

Exercise care in packing the materials to be returned. The shipper will be advised of any damage due to improper packing, and no further action will be taken in connection with this material return until the shipper provides clearance for further disposition.

SECTION 10

SPARE PARTS

When ordering spare parts, contact Forney's Spares Department via any one of the following methods and furnish the following information.

Mail	Phone	Fax
Attn: Spare Parts Forney Corporation 16479 North Dallas Parkway Suite 600 Addison, TX 75001	(972) 458-6100 or (972) 458-6142 or 1-800-356-7740 (24-hour direct line)	(972) 458-6600

1. Contract number
2. Customer purchase order number
3. For each part ordered, provide the following information:
 - a. Part number
 - b. Part description
 - c. Quantity required

The recommended spare parts list in Table 10-1 advises of the minimum stock level of replacement parts that should be in the customer's stock for system startup and the first year of operation. Replacement parts should be ordered as necessary to maintain the suggested stock of spare parts at the recommended level.

10-1 Recommended Spare Parts List

Part Description	Part Number					Quantity
Ignition Spark Source						
HESI Tip, Short HESI Tip, Long	383726-02 383726-03					1 for every 5 igniters
HTSI	369310-xx (see HTSI Manual)					
Miscellaneous	MAXFire® 110	MAXFire® 130	MAXFire® 135	MAXFire® 140	MAXFire® 150	
Head Gasket (Silicone)	383714-02	369156-01	369110-01	369110-01	369511-01	1 for every 5 igniters
Head Gasket (Viton)	383714-01	369156-02	369110-02	369110-02	N/A Call Forney	
Mount Tube Clamp (Hand Actuated)	91102-00	91102-03	91102-06	91102-06	N/A Call Forney	
Mount Tube Clamp (With Two Bolts)	91102-02	91102-05	91102-07	91102-07	N/A Call Forney	