



BURNERPRO APPLICATIONS

August 2020



Introduction

Designed as drop-in replacement for Siemens LFL

The BurnerPRO was originally designed to be a drop-in replacement for the Siemens LFL. The BurnerPRO can mount into the same wiring base, has the same terminals and offers models with similar timings to most LFL models. The BurnerPRO replaces the electro-mechanical design with modern non-volatile microprocessor control.



Features

- Non-volatile lockout capability
- Proof of fuel valve closure input
- Air-flow switch test input
- A run/check feature which allows the operator to stop the program sequence in different positions (Purge, Ignition, PTFI and MTFI) for commissioning
- Remote and local reset
- Real-time internal diagnostics for added safety integrity
- Modbus for programming timings or remote monitoring
- Pre-programmed operational timings available for quick change out
- Built-in amplifiers for flame monitoring with UV, flame rod or both
- Model with valve proving available

Sequence

- Accepts call for heat from completed recycle limit input
- Initiates a burner sequence
- Checks proof of closure switches
- Checks the normally closed and normally open positions of airflow switch
- Handshake with external actuator for damper positioning (economy, low-fire, high-fire and auto)
- Terminals for direct ignition and piloted systems (interrupted or intermittent)
- Wiring options for no prepurge, postpurge or no purge at all
- POC, airflow switch check and actuator control can all be disabled via wiring jumpers

Sequence diagram

Without valve proving

Interrupted pilot

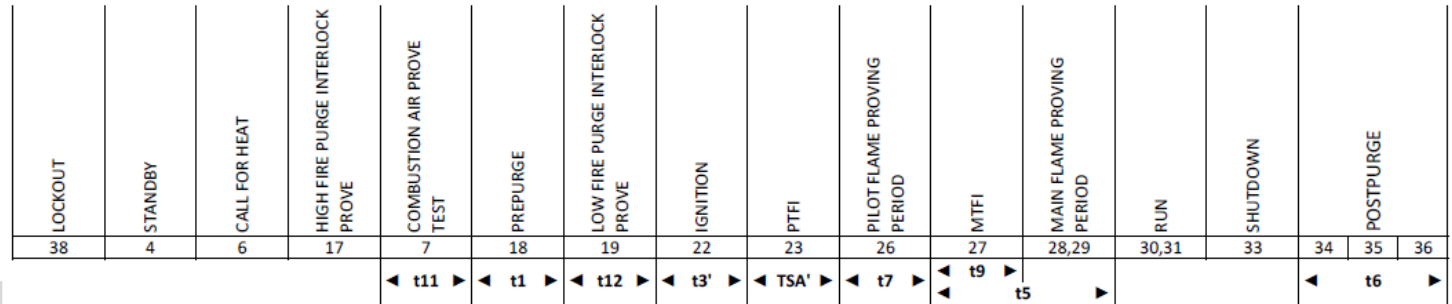

TYPE	TERMINAL	DESCRIPTION
OUTPUT	3	Alarm
OUTPUT	4	Power to limits
INPUT	5	Recycle limits
INPUT	12	Proof of closure
INPUT	13	Combustion air switch test
INPUT	14	Combustion air proven
OUTPUT	6,7	Blower
OUTPUT	16	Ignition
OUTPUT	17	Pilot gas valve
OUTPUT	19	Main gas valve
INPUT	8	Actuator feedback
OUTPUT	9	Actuator open (high fire purge)
OUTPUT	10	Actuator minimum (low fire ignition)
OUTPUT	11	Actuator economy (closed)
OUTPUT	20	Release to modulate
INPUT	22,23	Flame signal UV
INPUT	24, G	Flame signal flame rod
		Flame signal results in lockout
		Flame fail results in postpurge



Sequence timings

Standard timings S1-S6

Without valve proving:

TIMINGS / STATE SEQUENCE											
PRESET	FFRT		t11	t1	t12	t3'	TSA'	t7	t9	t5	t6
S1	1s	Actuator travel time (max = feedback time)	35.5s	31s	37s	6s	2s	8s	2s	10s	12s
S2	1s										18s
S3	1s										15s
S4	1s										15s
S5	4s										15s
S6	4s										15s

With valve proving:

TIMINGS / STATE SEQUENCE													
PRESET	FFRT		t11	t1	t12	t3'	TSA'	t7	t9	t5	t6	VPT1	VPT2
S1	1s	Actuator travel time (max = feedback time)	35.5s	31s	37s	6s	2s	8s	2s	10s	12s	30s	30s
S2	1s										18s	30s	30s
S3	1s										15s	30s	30s
S4	1s										15s	30s	30s
S5	4s										15s	30s	30s
S6	4s										15s	30s	30s

Diagnosics and status

- Continuous flame monitoring with UV scanner and/or flame rod
- Alarm relay is used to annunciate the presence of a lockout condition
- Smart LEDs annunciate burner sequence states and lockout codes
- Smart LEDs can be used to show flame signal on demand in 20% increments
- “Check” mode can be used during commissioning, adjustment, and maintenance
- Microprocessor based control has continuous internal checking to ensure high safety integrity

Smart LEDs

Seven Smart LEDs provide operating status and lockout information



LED Lights

FAN
OPEN DAMPER
CLOSE DAMPER
AUTO
IGNITION
FLAME
ALARM

Ready to Burn

UV scanners

UV1AL

The UV1AL series scanners are designed for front mounting which may allow the scanner to obtain a clearer view of the flame. The UV1AL comes with either a 3' or 6' TC-ER rated cable attached. The UV1AL has a ½" NPT female thread for mounting directly to a sight pipe.



UV1AL

The UV1AL, UV90L and UV5 ultra-violet flame scanners are non-self-checking and should be applied only to burners that cycle a minimum of once per 24 hours.

UV scanners

UV90L

The UV90L series scanners are designed for front and lateral (90°) mounting which may allow the scanner to obtain a clearer view of the flame. The UV90L provides a field wired terminal block.



UV90L (Cable purchased separately)

The UV1AL, UV90L and UV5 ultra-violet flame scanners are non-self-checking and should be applied only to burners that cycle a minimum of once per 24 hours.

UV scanners

UV5

The UV5 series scanners are designed for front and lateral (90°) mounting which may allow the scanner to obtain a clearer view of the flame. The UV5 provides a detachable 80" UL rated cable.



UV5

The UV1AL, UV90L and UV5 ultra-violet flame scanners are non-self-checking and should be applied only to burners that cycle a minimum of once per 24 hours.

UV scanners

UV1AL

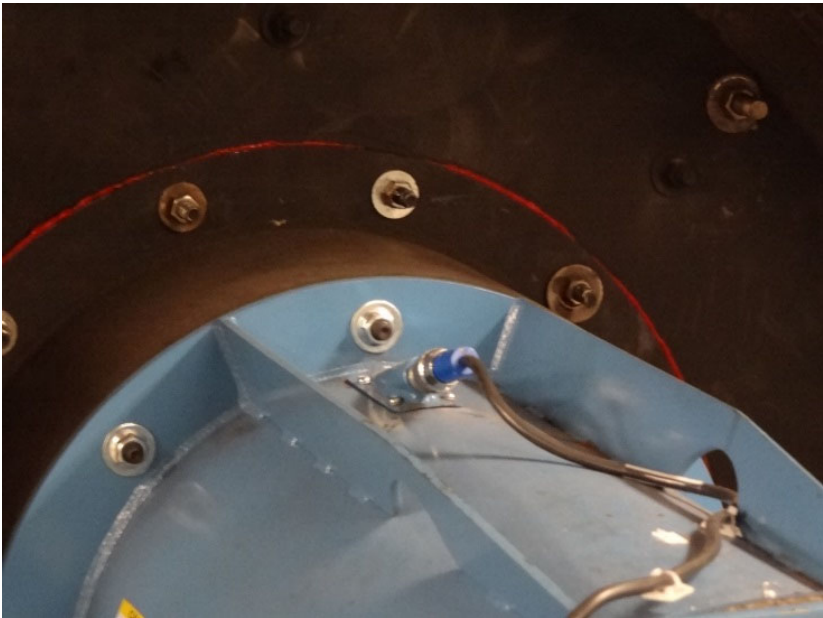

UV90L

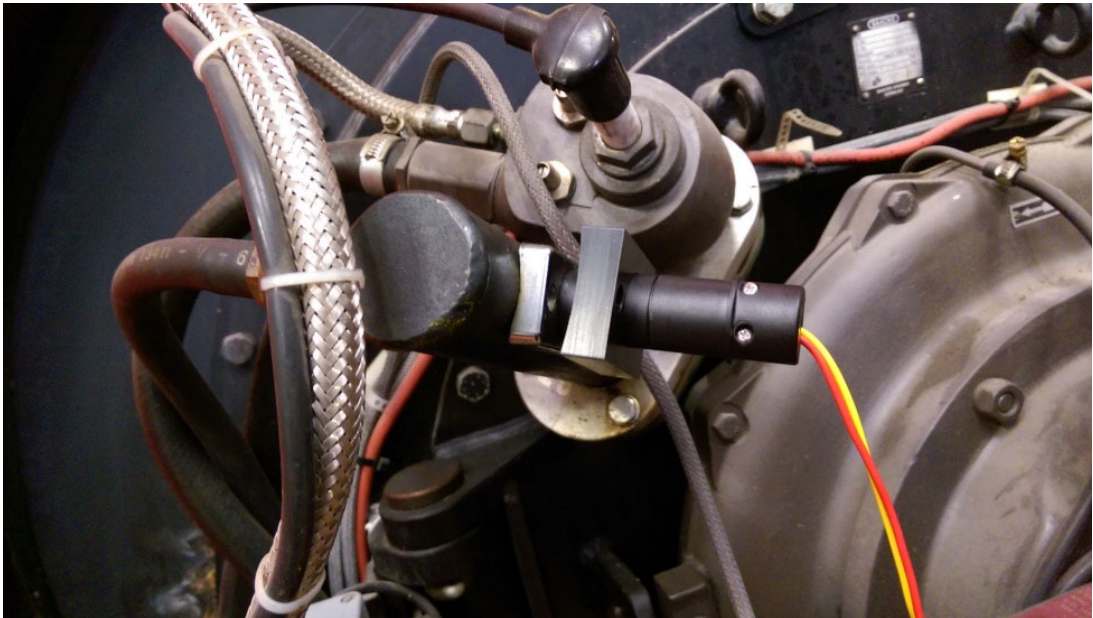

UV scanners

Installation

- Where possible, obtain the burner manufacturer's instructions for mounting the scanner.
- Position the UV1AL, UV90L or UV5 scanner within 39 inches (one meter) of the flame to be monitored.
- Select a scanner location that remains within the ambient temperature limits of the UV scanner
 - **UV1AL:** -40°C to +90°C (-40°F to +194°F)
 - **UV90L:** -40°C to +90°C (-40°F to +194°F)
 - **UV5:** -20°C to +60°C (-4°F to +140°F)
- Install the scanner on a ½" NPT pipe whose position is rigidly fixed (UV1AL)

Flame rod

69ND1

Fireye offers the 69ND1 flame rod for use with the BurnerPRO. It is not a requirement that this specific flame rod is used – any flame rod or design using the flame rod principle to detect flame can be used.



Wiring base

Neutral junction

The wiring base offers three terminals for connecting device neutrals. This junction strip is connected to terminal 2 with an integrated jumper link.

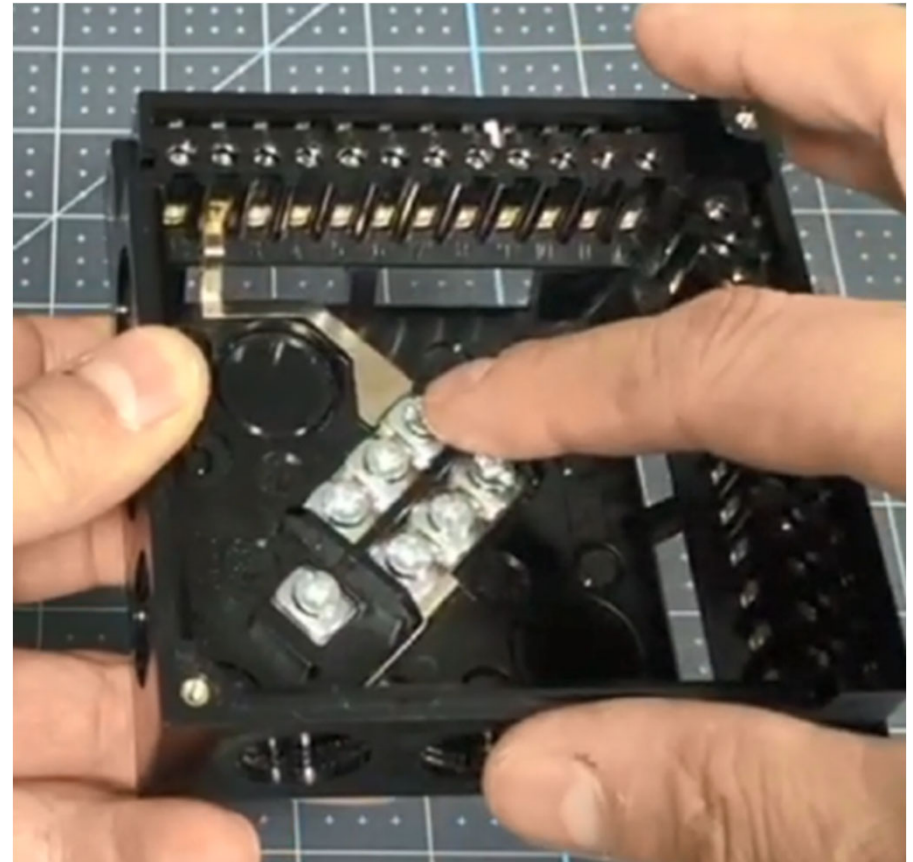

Wiring base

Grounding junction

The wiring base offers three terminals for connecting device grounds. This junction strip is connected to the back panel through a link and metal connection that is exposed on the back of the wiring base.

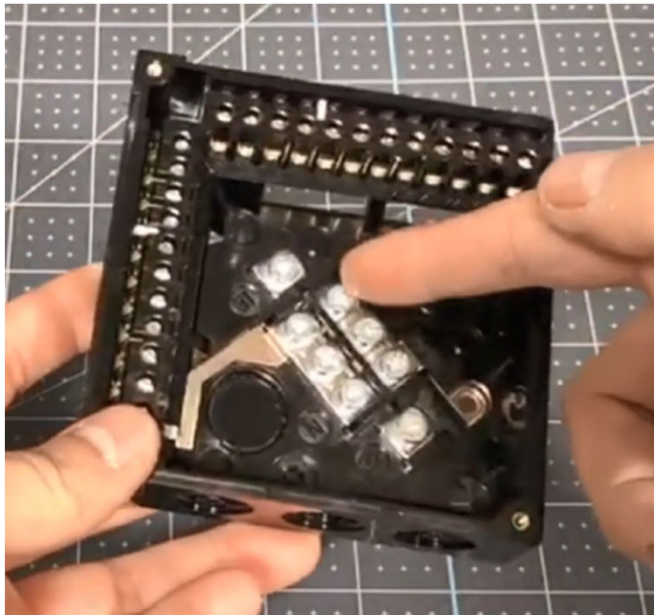

Terminal designations

Without valve proving

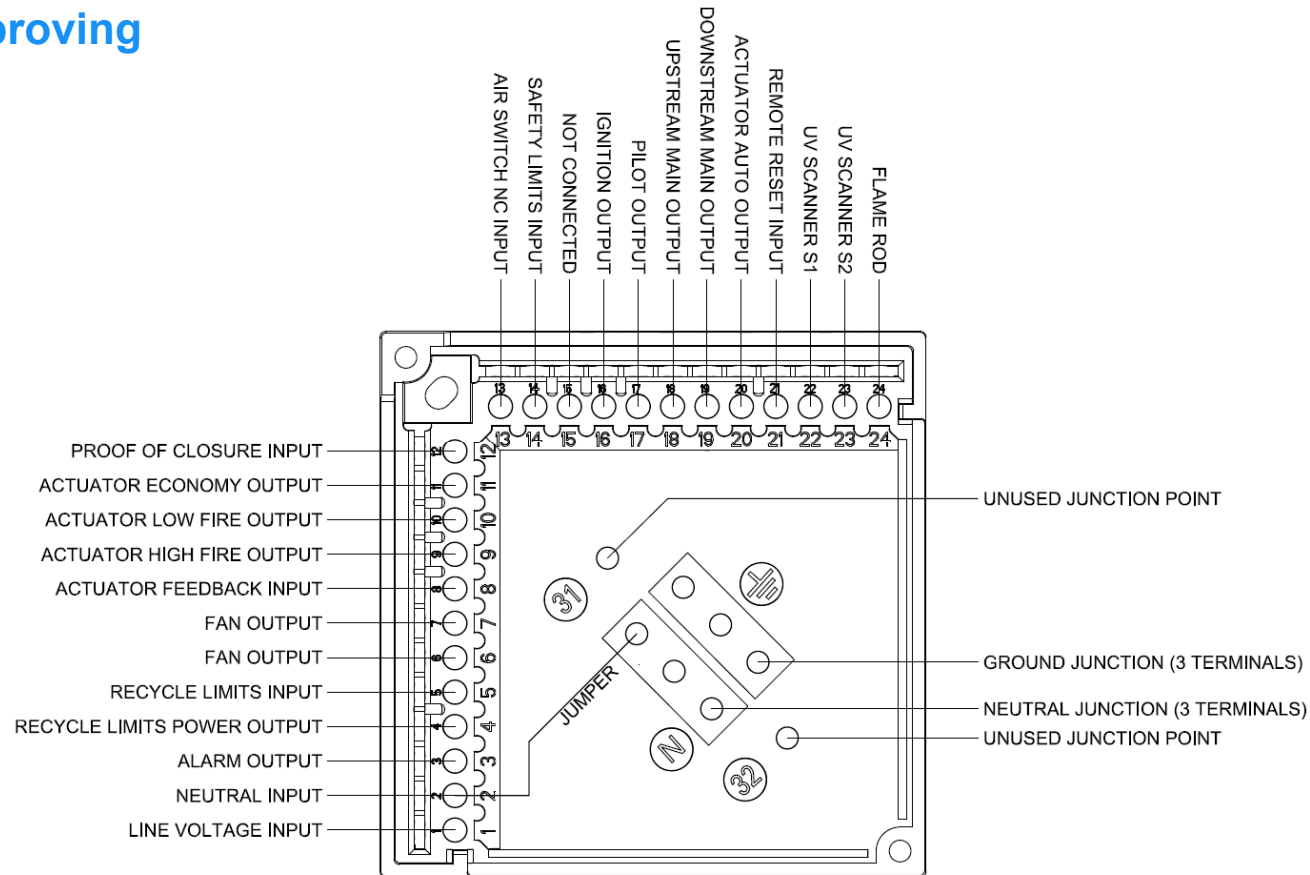

Terminal designations

With valve proving

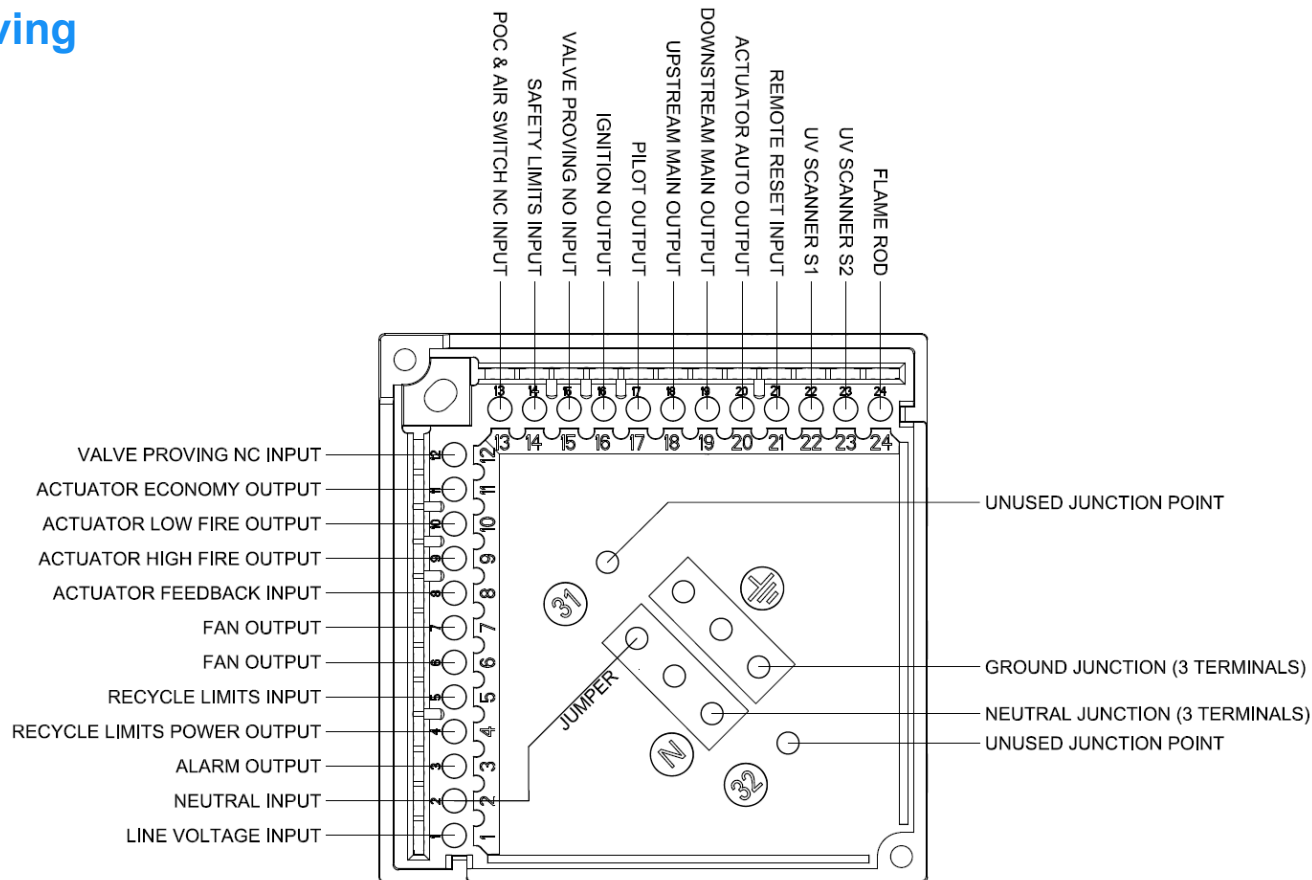

Wiring examples

EXAMPLE WIRING DIAGRAM FOR MODULATING BURNER w/ INTERRUPTED PILOT CONFIGURED FOR VALVE PROVING

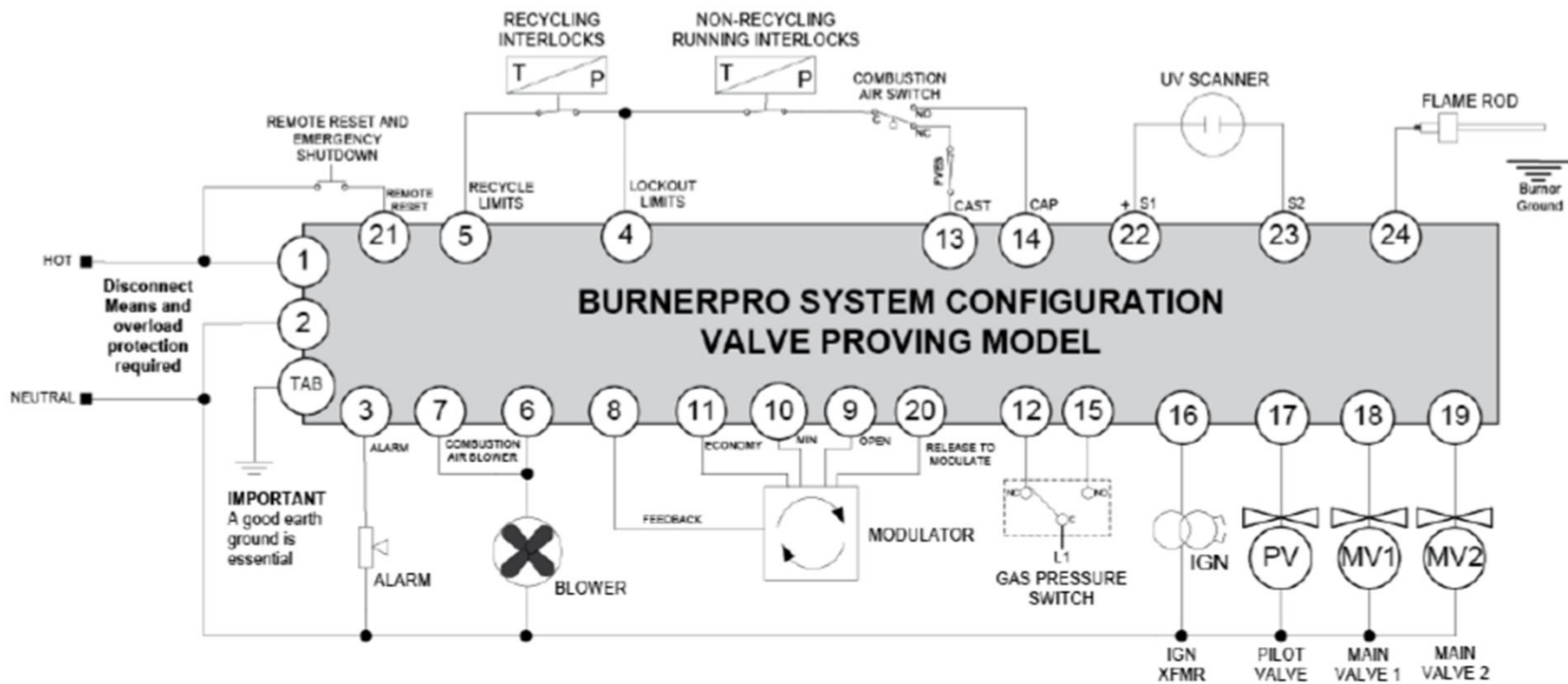

Wiring examples

EXAMPLE WIRING DIAGRAM FOR BURNER w/ DIRECT IGNITION

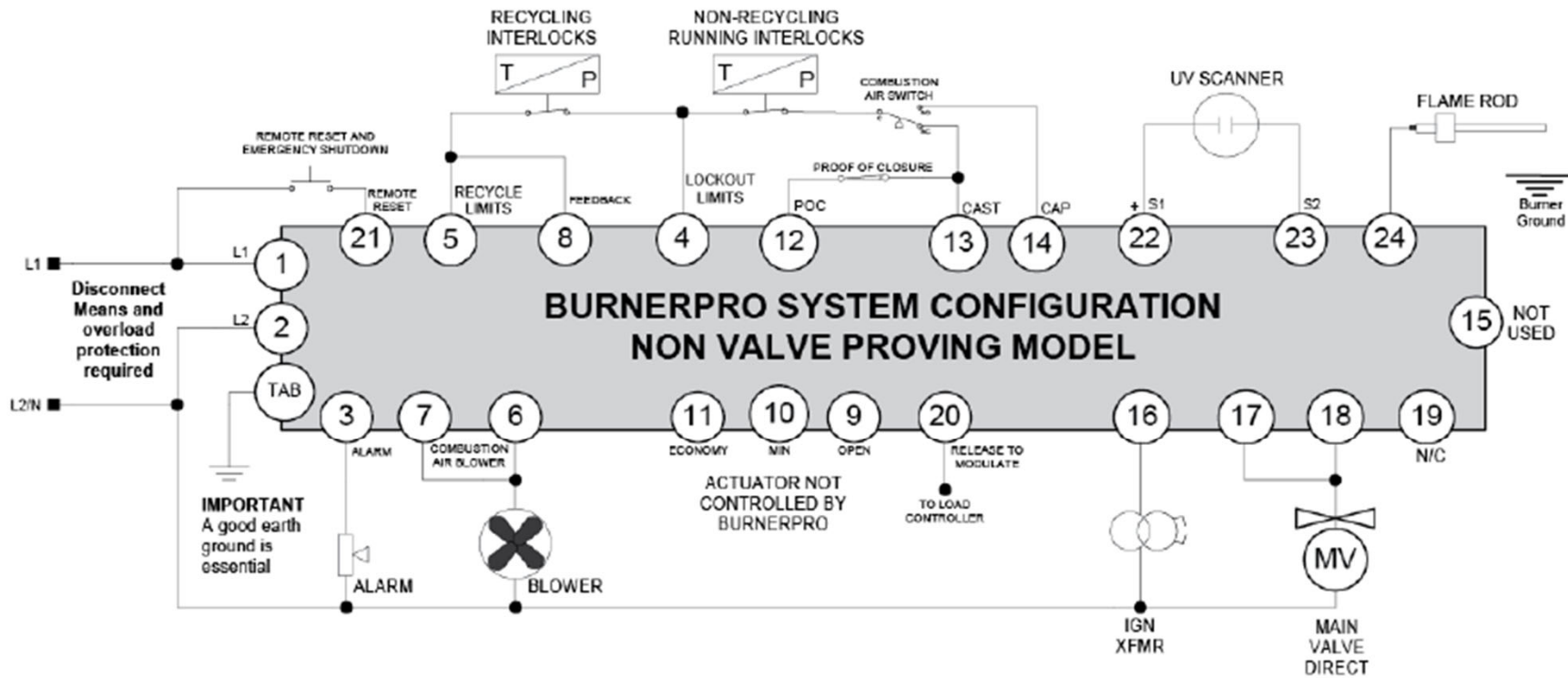

Wiring examples

EXAMPLE WIRING DIAGRAM FOR MODULATING BURNER w/ INTERMITTENT PILOT

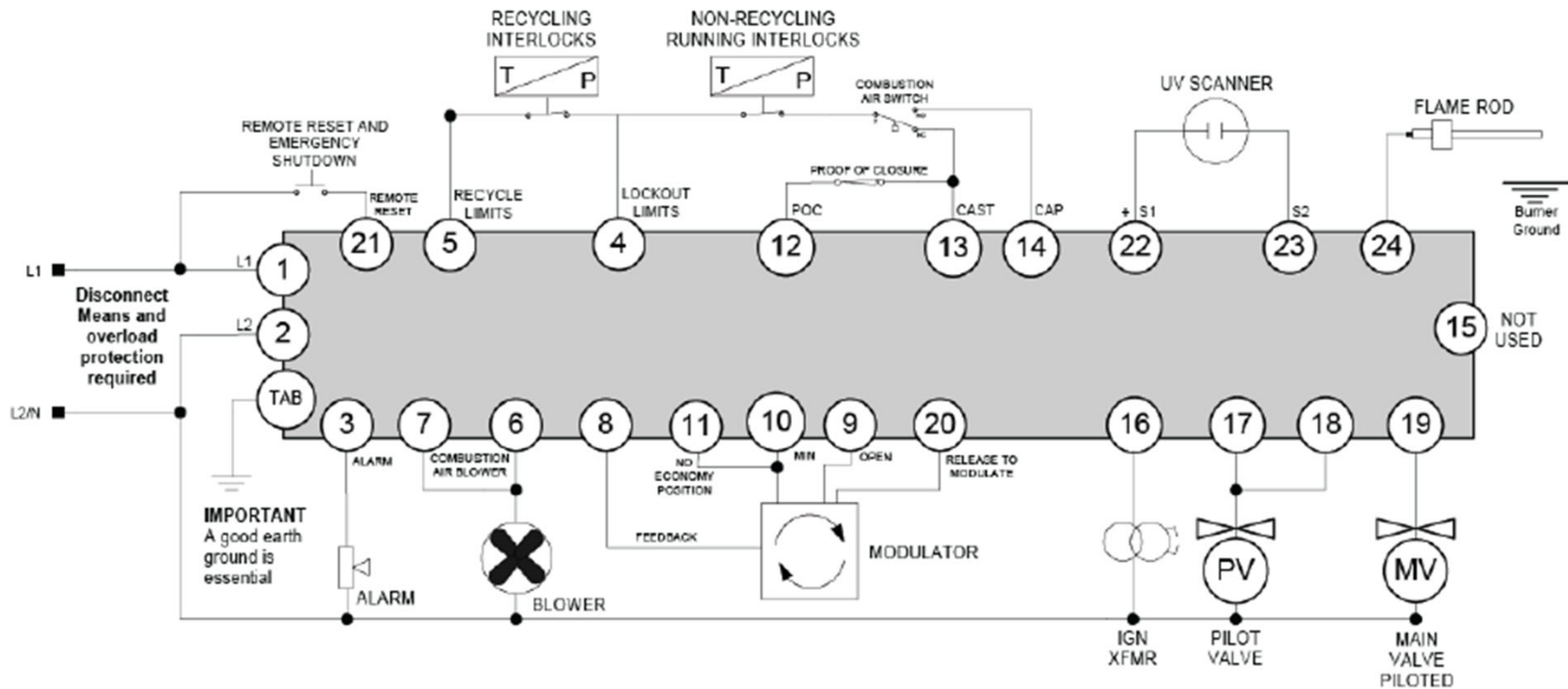

Wiring examples

Zero purge is achieved by a simple “linking out” of terminals in the wiring base

Green Link = No Pre-purge
 Blue Link = No Post Purge
 Red link = No purge at all

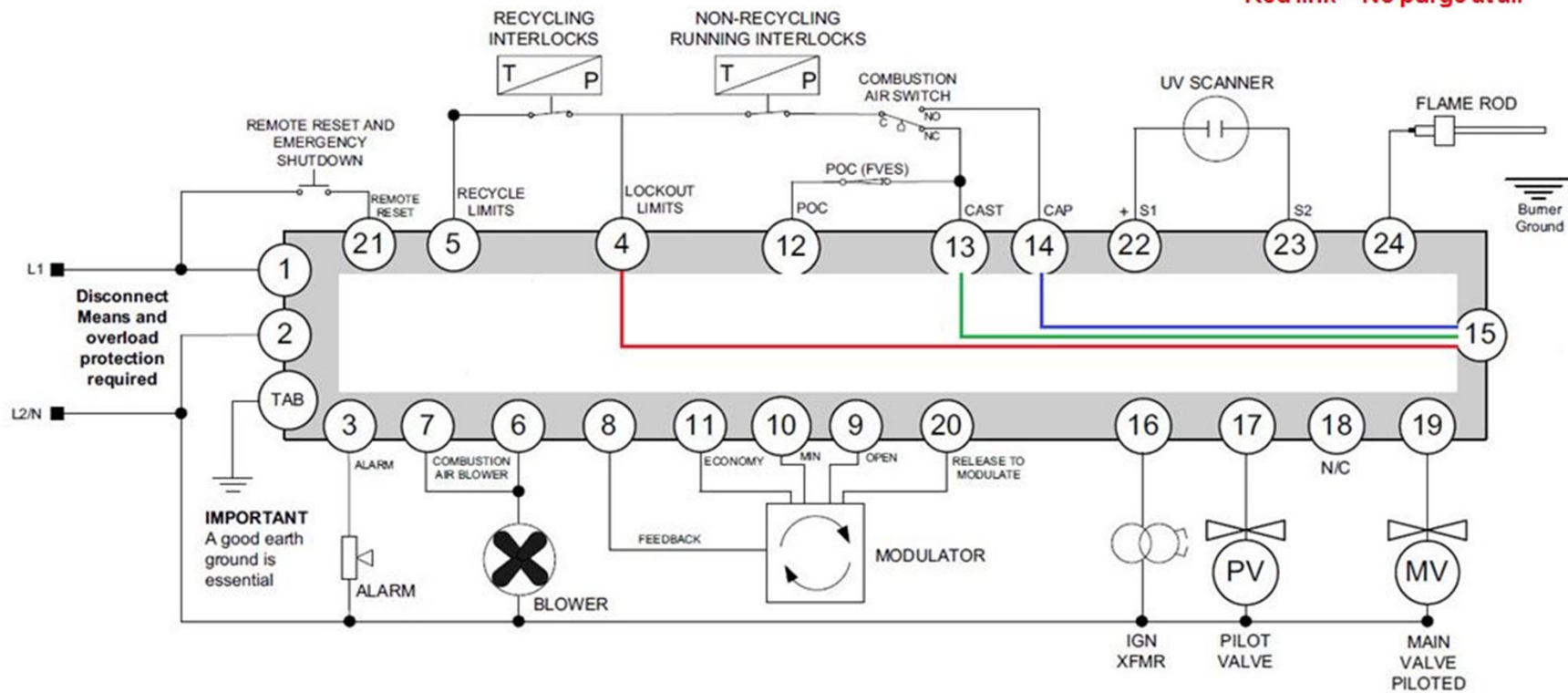

Retrofits for Siemens LFL

The BurnerPRO is a drop-in replacement for the Siemens LFL. This means that the existing wiring base can be retained since it is approved for use and is functionally equivalent. The only steps for replacement are to:

1. Select the proper timing for the BurnerPRO from the cross-reference chart to the right.
2. Remove LFL copper grounding spring and replace with BurnerPRO grounding leash.
3. If a UV scanner is used, remove from terminals 22-23 and replace with Fireye UV1AL(-3)(-6). If a flame rod is used, that can be retained.

LFL	BurnerPRO
LFL1.322	BP230UVFR-S1M
LFL1.322-110V	BP110UVFR-S1M
LFL1.333	BP230UVFR-S2M
LFL1.333-110V	BP110UVFR-S2M
LFL1.335	BP230UVFR-S3M
LFL1.335-110V	BP110UVFR-S3M

Replacement for Honeywell 7800

Single control, no accessory parts

The 7800 control, amplifier card, purge card and keyboard display module can all be replaced with a single BurnerPRO. No additional accessories are required.



Replacement for Honeywell 7800

There is a BurnerPRO model to replace most models of Honeywell 7800 that use a UV scanner or a flame rod. There are many preset timings available to fit most applications, or user-defined timings can be applied to any model by using the **Config Wizard for BurnerPRO** software.

For Honeywell 7800 applications that use an infrared scanner, a UV self-checking scanner, or require an expanded annunciator, the BurnerLogix flame safeguard is a great alternative.

See *Fireye BurnerPRO Replacement Options for Honeywell 7800 Series* and *Fireye BurnerLogix Replacement Options for Honeywell 7800 Series* documents on the Fireye website (www.fireye.com) for more information.

Wiring base adapter

Mounts directly onto 7800 wiring base

The wiring adapter mounts on top of the 7800 wiring base.



Wiring base adapter

BurnerPRO base mounting options

The prewired BurnerPRO wiring base can be mounted beside or on top of the wiring base adapter.



Wiring base adapter

There are two models of wiring base adapter:

- **60-2991-1:** Applications that used the RM7800/RM7840/RM7845
- **60-2991-2:** Applications that used the RM7895/RM7897

The difference is primarily in wiring between the different Honeywell 7800 models. There are also four preset timings available that best match gas and oil uses for both on/off and modulating applications. Timings can also be changed as needed using the **Config Wizard for BurnerPRO** software.

Multi-burner applications

The BurnerPRO is a great fit for multi-burner applications due to the small size and flexibility it provides with fewer parts and variations. Since there are only two models (with and without valve proving), all other options and timings can be changed with **Config Wizard for BurnerPRO** software or by the type of wiring connection that is made. Prepurge, postpurge or both can be skipped with a simple wire connection.



Multi-burner applications

Using the BurnerPRO saves money since the overall package can be made smaller. If Modbus is used, this can also make the BurnerPRO much more economical since both the Honeywell 7800 and Siemens LME7 require external devices to make Modbus available. For the LME7, this device requires additional mounting space as well.

Control	Footprint	Height	Modbus
BurnerPRO	101.6mm x 101.6mm (4" x 4")	127mm (5")	Standard feature via RJ45 jack
BurnerLogix	177.8mm x 101.6mm (7" x 4")	139.7mm (5.5")	Standard feature via RJ9/RJ10/RJ22 jack
Honeywell 7800	127mm x 127mm (5" x 5")	133.3mm (5.25")	Via S7800A or S7810M, fits within footprint
Siemens LME7	180mm x 120mm (7.09" x 4.72")	52.5mm (2.07")	Via OCI417.10, requires mounting space of 35mm x 89.6mm x 31.25mm (1.38" x 3.53" x 1.23")

Modbus

The standard Modbus connection on the generation 3 models is Modbus RTU via RS-485. The physical connection is via an RJ-45 connector. The Modbus connection uses pin 5 for Modbus A+ and pin 4 for Modbus B- (these are the center two pins).

Available baud rates are 4800, 9600, 19200 and 38400. Parity is none with eight data bits and one stop bit.

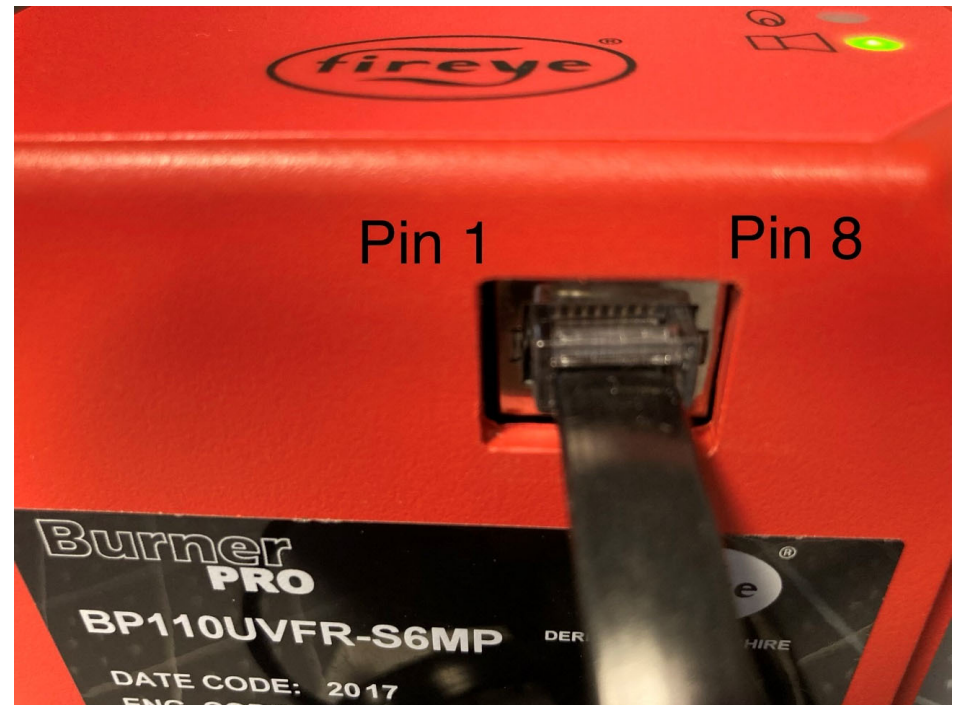

Modbus

Connecting multiple units via Modbus can be done using either an RJ-45 splitter (must be pin for pin) or an ED610 communication breakout board. If using the ED610, ED580 cables may be used to connect between units. Standard Cat5 cable may be used if it conforms to Modbus requirements for the application. These two methods can also be used in combination (ED610 for the first unit to provide terminals, then splitters after to the rest of the units).

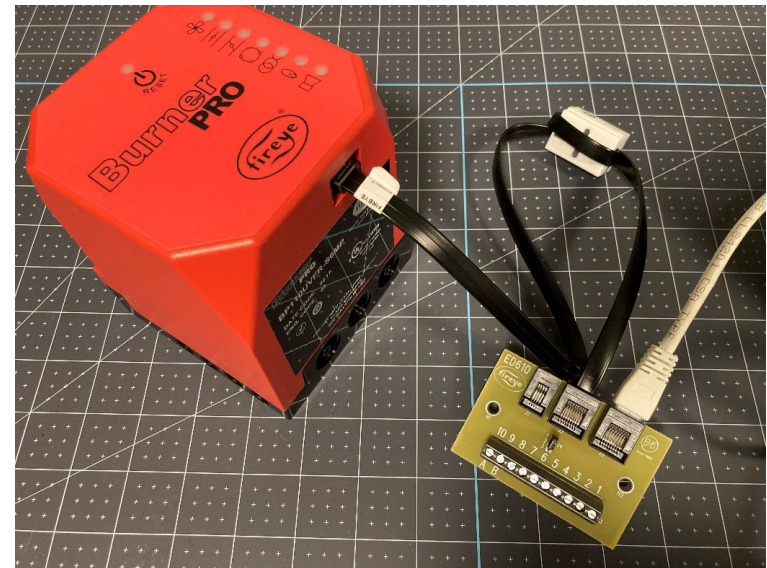
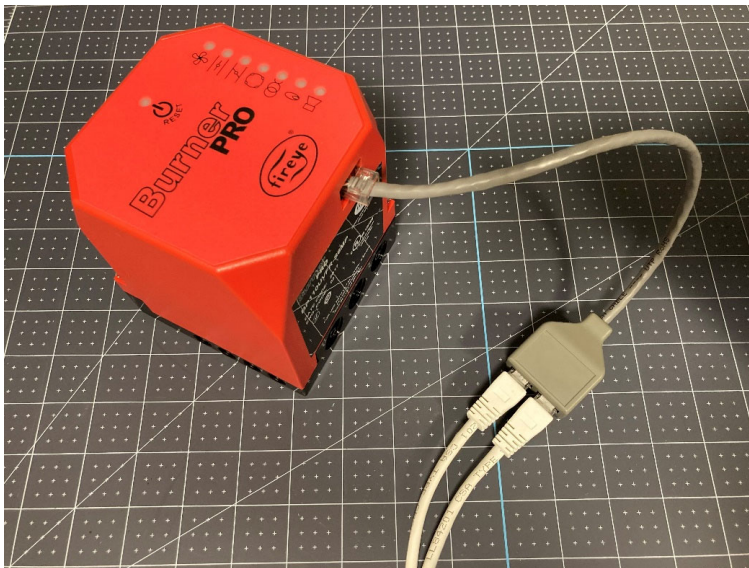

Config Wizard for BurnerPRO

Software is available to configure timings and other options. A programming cable is used to initiate a special mode which will allow changing of parameters. While programming, the unit will shut down and will require a reset at the conclusion of programming.

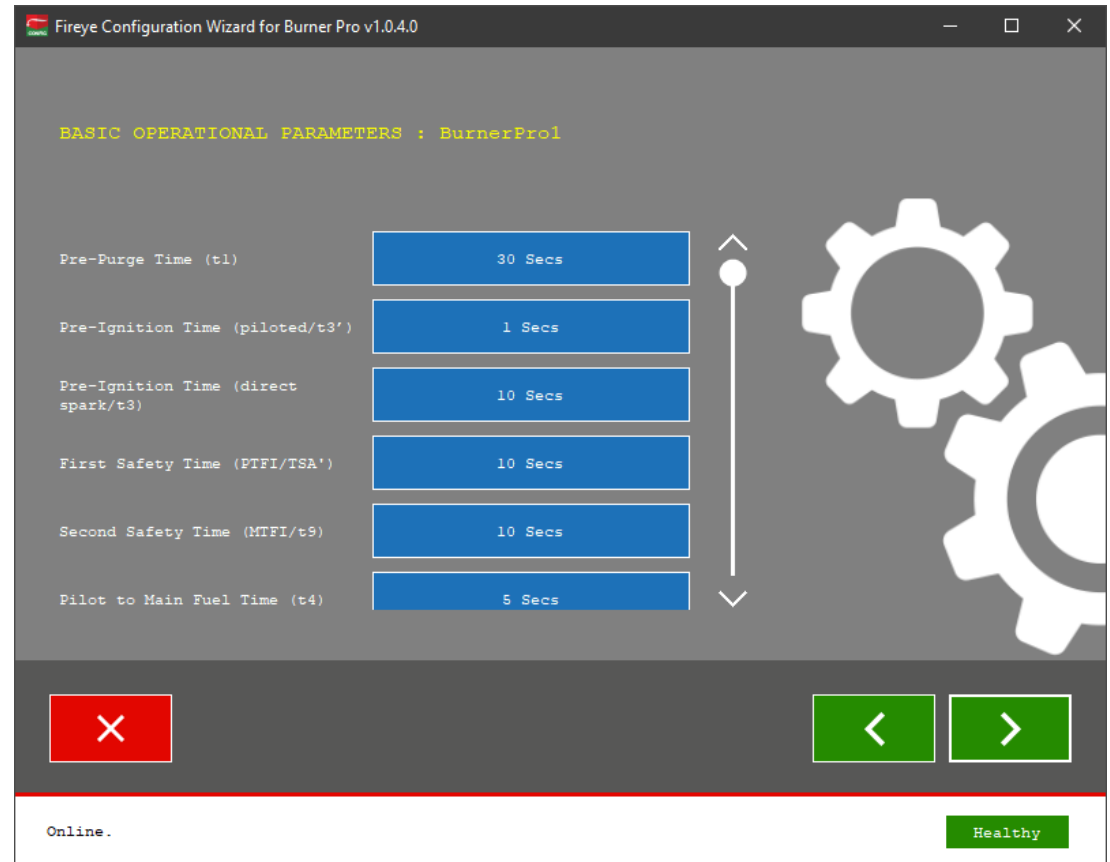

BP500 tester



BP500

Tester allows demonstration or troubleshooting of a BurnerPRO control. It is portable and powered by a standard wall plug. Flame signal is automated or a compatible UV scanner or flame rod may be connected.

Conclusion

With a compact footprint and standard Modbus connectivity, the BurnerPRO is the most economical choice for a flame safeguard in a modern burner or multi-burner application. The versatility of the control also makes it perfect for users that would normally require many different variations of flame safeguard, potentially requiring less spare parts and reducing downtime.

The BurnerPRO is also perfect as a replacement control for other flame safeguards, whether as a direct drop-in replacement or using the adapter base. This allows an OEM to migrate to the BurnerPRO while being able to provide existing customers up-to-date replacements.



THANK YOU

